

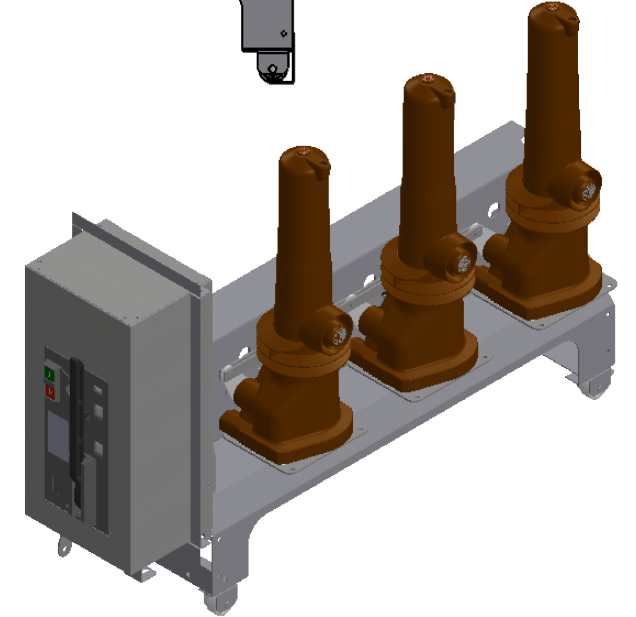

REVİZYONLAR

REV. NO	AÇIKLAMA	TARİH	REVİZYON YAPAN
---------	----------	-------	----------------

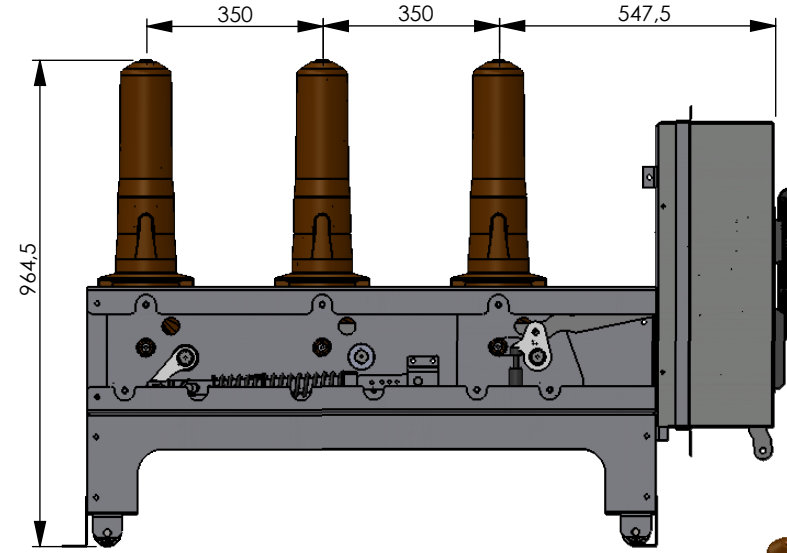
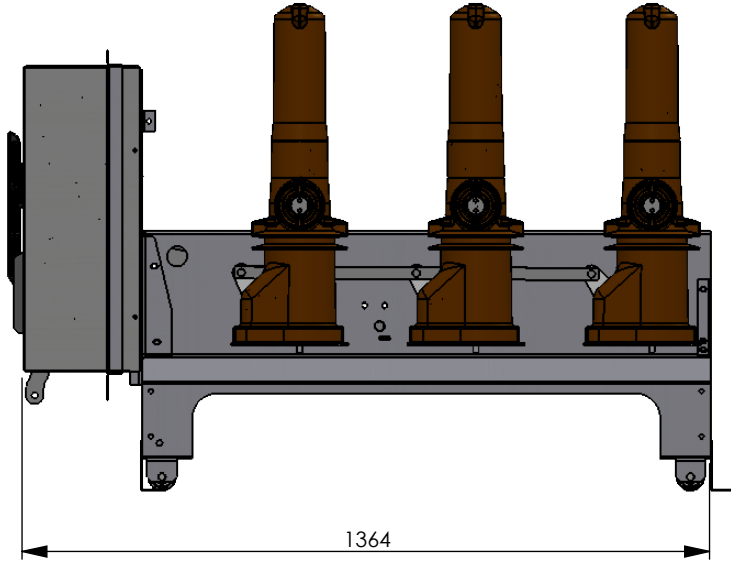

Genel Toleranslar-General Tolerances (ISO 2768-m)						Parça Adı-Part Name	Malzeme-Material	MONTAJ RESMİ-	Tarih-Date	İmza-Signature	Sayfa-Sheet	1/1
0,5-6	6-30	30-120	120-400	400-1000	1000<	36kV 630A SF6 GAZLI KESİCİ	Çizen-Drawn By	B.ERDOĞAN	9.12.2023		Ölçek-Scale	A4 1:15
±0,1	±0,2	±0,3	±0,5	±0,8	±1,2		Kontrol-Checked By	A.OCAK			Yön-Direction	
Açısal Toleranslar-Angular Tolerances							Resim No-Draw No	Ağırlık- Weight (gr.)	121893,71			
<10°	10°<50°	50°>120°	>120°			Kaplama Cinsi-Plating Type						
±1°	±0,5°	±0,3°	±0,2°			Kap. Kalınlığı-Plating Thick.	μ 12446266,64					
						e-MOR: 01011701-00001						