

REVİZYONLAR

REV. NO	AÇIKLAMA	TARİH	REVİZYON YAPAN
---------	----------	-------	----------------

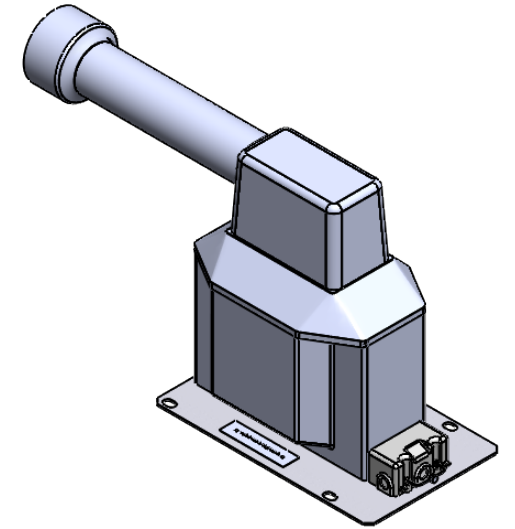
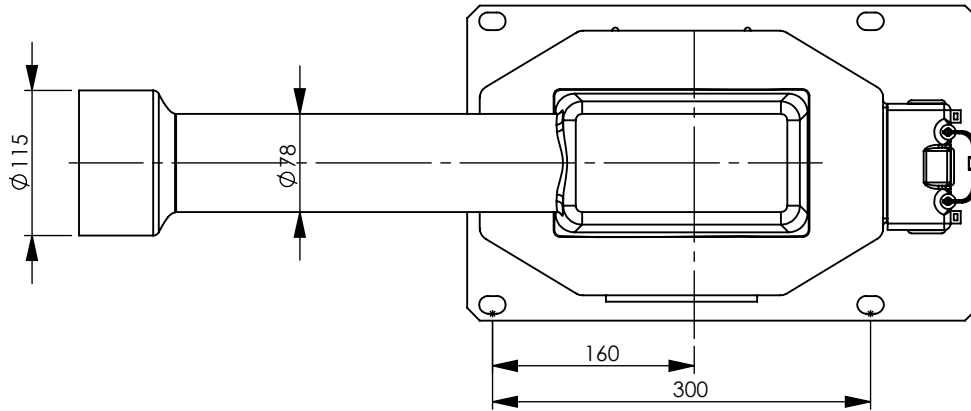
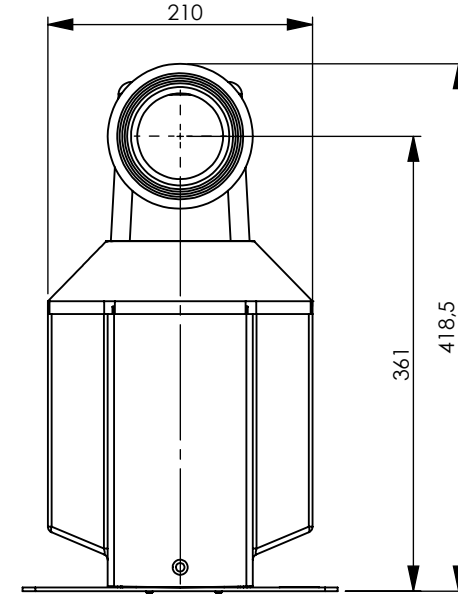
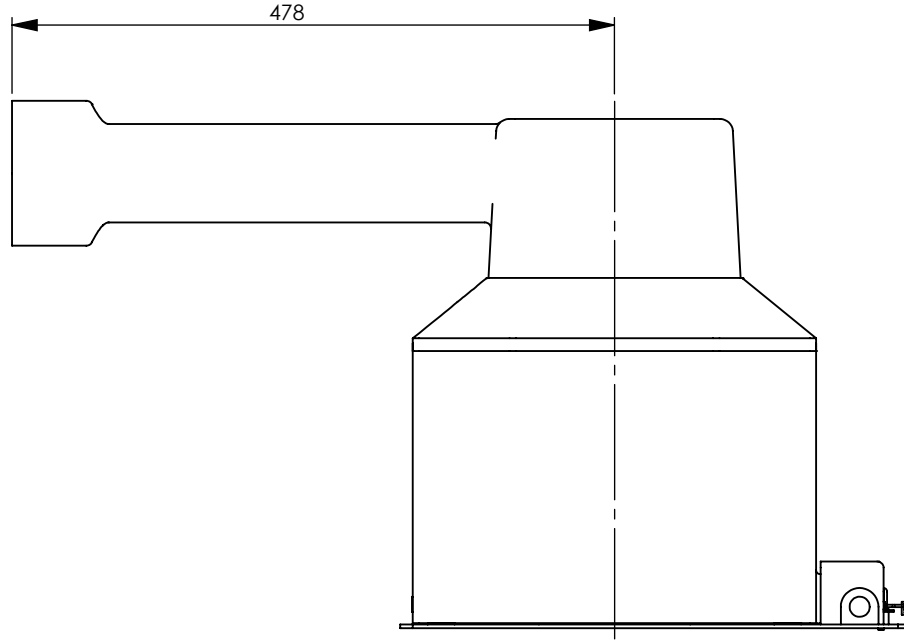

Genel Toleranslar-General Tolerances (ISO 2768-m)					
0,5-6	6-30	30-120	120-400	400-1000	1000<
±0,1	±0,2	±0,3	±0,5	±0,8	±1,2
Açısal Toleranslar-Angular Tolerances					
<10°	10°<50°	50°>120°	>120°		
±1°	±0,5°	±0,3°	±0,2°		

Parça Adı-Part Name

ARVT-M36WF-T

Resim No-Draw No

VTOG_00007

e-MOR:

Malzeme-Material	MONTAJ RESMİ-	Tarih-Date	İmza-Signature	Sayfa-Sheet	1/1
Çizen-Drawn By	B.ERDOĞAN	30.03.2023		Ölçek-Scale	A4 1:6
Kontrol-Checked By	A.OCAK			Yön-Direction	
Ağırlık- Weight (gr.)	17451.13				
Kaplama Cinsi-Plating Type					
Kap. Kalınlığı-Plating Thick.	μ 1010507.3				