

REVİZYONLAR

REV. NO	AÇIKLAMA	TARİH	REVİZYON YAPAN
---------	----------	-------	----------------

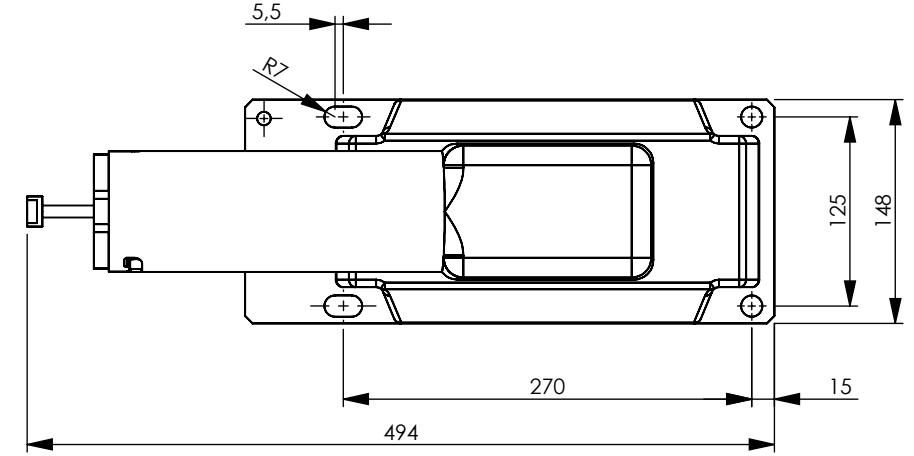
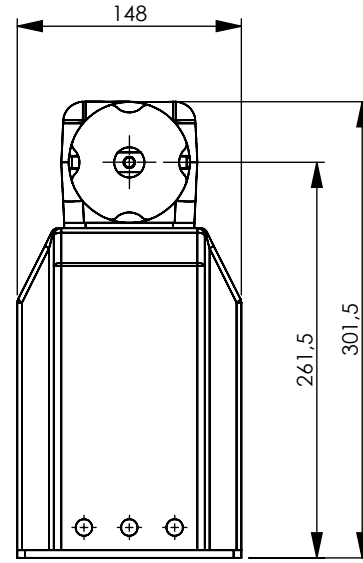
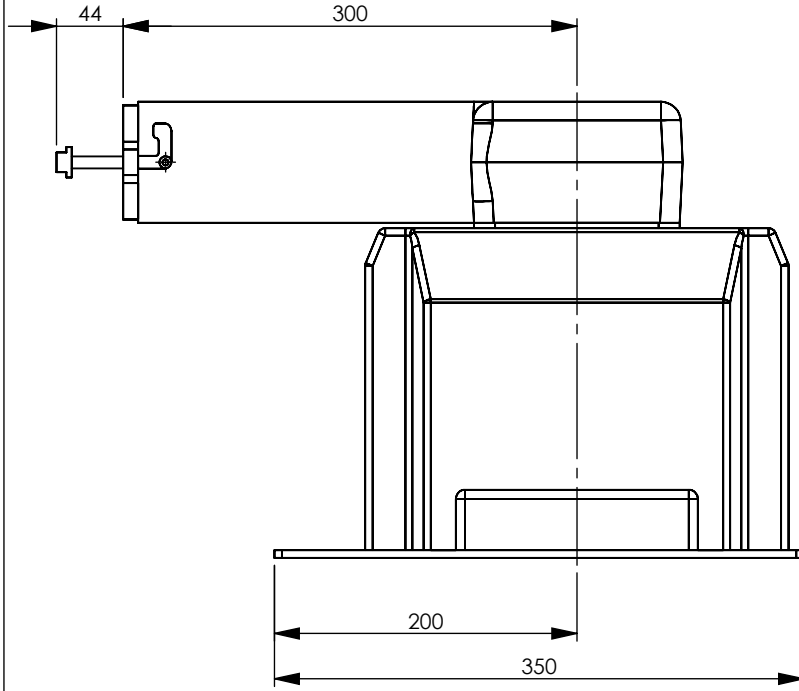

DİŞ	SIKMA TORKU
M5	2-2,5
M8	16-20

Genel Toleranslar-General Tolerances (DIN 7168 m)						Parça Adı-Part Name ARVT-M12WF GERİLİM TRANSFORMATÖRÜ	Malzeme-Material Malzeme <belirli değil>	Tarih-Date 22.07.2022	İmza-Signature	Sayfa-Sheet 1/1				
0,5-6	6-30	30-120	120-400	400-1000	1000<						Çizen-Drawn By C.ÖZER	Ölçek-Scale A4 1:5		
±0,1	±0,2	±0,3	±0,5	±0,8	±1,2						Kontrol-Checked By N.DENİZOĞLU	Yön-Direction ↔ ⊕		
Açısal Toleranslar-Angular Tolerances						Resim No-Draw No CTOG_00077	Ağırlık- Weight (gr.) 17494.98	Kaplama Cinsi-Plating Type	Kap. Kalınlığı-Plating Thick. μ	armtek ELEKTRİK				
<10°	10°<50°	50°>120°	>120°	e-MOR:										
±1°	±0,5°	±0,3°	±0,2°											