

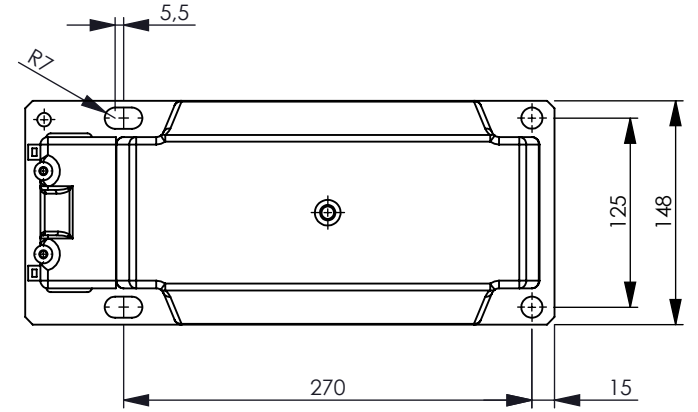

REVİZYONLAR

REV. NO	AÇIKLAMA	TARİH	REVİZYON YAPAN
---------	----------	-------	----------------

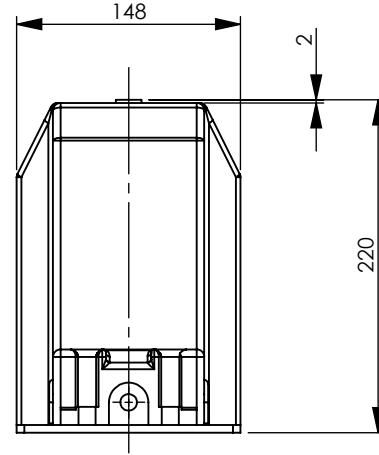
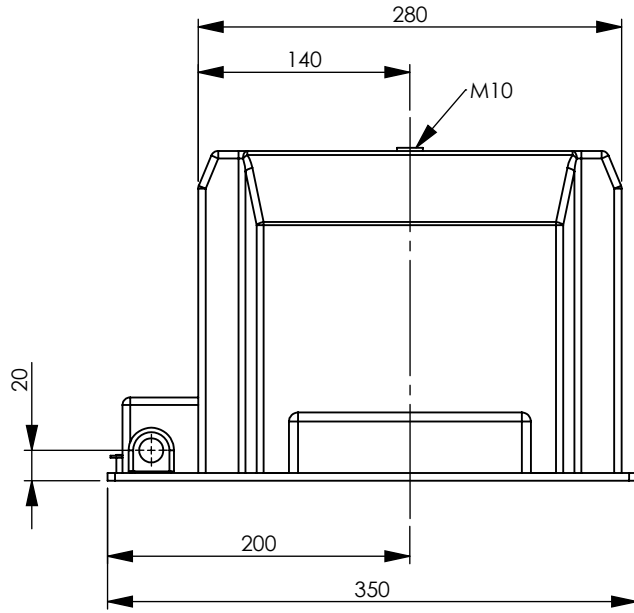

DİŞ	SIKMA TORKU
M5	2-2,5
M8	16-20
M10	40-50

Genel Toleranslar-General Tolerances (DIN 7168 m)						Parça Adı-Part Name	Malzeme-Material	Malzeme <belirli değil>	Tarih-Date	İmza-Signature	Sayfa-Sheet	1/1
0,5-6	6-30	30-120	120-400	400-1000	1000<	ARVT-M12 GERİLİM TRANSFORMATÖRÜ	Çizen-Drawn By	C.ÖZER	19.07.2022		Ölçek-Scale	A4 1:5
±0,1	±0,2	±0,3	±0,5	±0,8	±1,2		Kontrol-Checked By	N.DENİZOĞLU			Yön-Direction	→ ⊕
Açısal Toleranslar-Angular Tolerances						Resim No-Draw No	Ağırlık- Weight (gr.)	17,38				
<10°	10°<50°	50°>120°	>120°	CTOG_00075		Kaplama Cinsi-Plating Type						
±1°	±0,5°	±0,3°	±0,2°	e-MOR:		Kap. Kalınlığı-Plating Thick.	μ					