

REVİZYONLAR			
REV. NO	AÇIKLAMA	TARİH	REVİZYON YAPAN

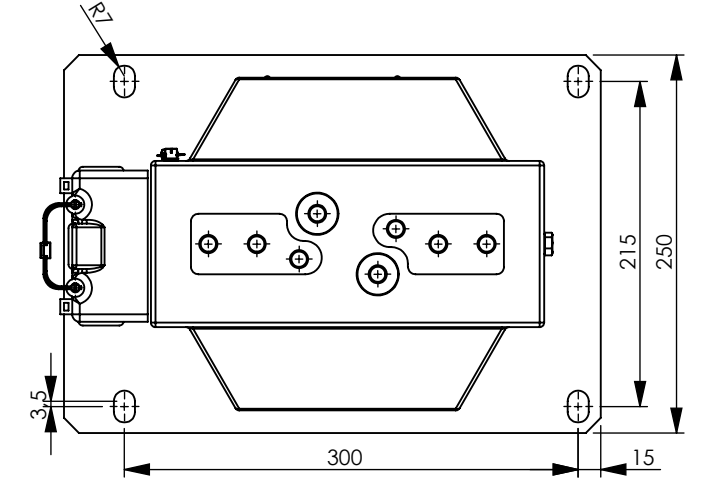

### PRİMER BAĞLANTI TERMİNALLERİ

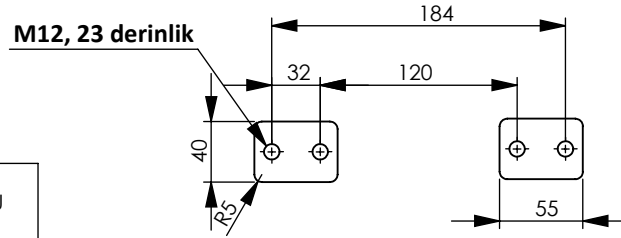

800 A'e kadar(Pirinç)  
800A < In ≤ 1500A(Bakır)

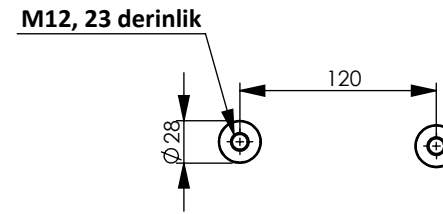

300 A'e kadar(Pirinç)  
300A < In ≤ 600A(Bakır)

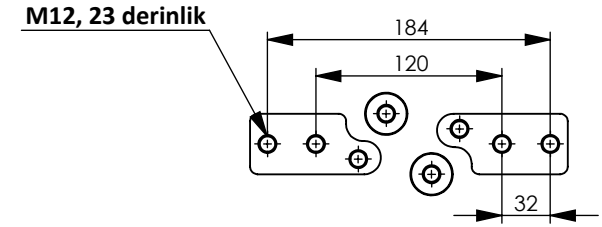

2x300A < In ≤ 2x600A

DİŞ	SIKMA TORKU
M5	2-2,5
M8	16-20
M12	60-70

Genel Toleranslar-General Tolerances ( DIN 7168 m )						Parça Adı-Part Name		Malzeme-Material		Tarih-Date	İmza-Signature	Sayfa-Sheet	1/1
0,5-6	6-30	30-120	120-400	400-1000	1000<	ARCT-B36/1 AKIM TRANSFORMATÖRÜ		Çizen-Drawn By		13.12.2021		Ölçek-Scale	A4 1:10
±0,1	±0,2	±0,3	±0,5	±0,8	±1,2			Kontrol-Checked By				Yön-Direction	
Açısal Toleranslar-Angular Tolerances						Resim No-Draw No		Ağırlık- Weight (gr.)					
<10°	10°<50°	50°>120°	>120°	CTOG_00005		30027.08		Kaplama Cinsi-Plating Type					
±1°	±0,5°	±0,3°	±0,2°	e-MOR:		Kap. Kalınlığı-Plating Thick.		μ		641829.74			

