

REVİZYONLAR			
REV. NO	AÇIKLAMA	TARİH	REVİZYON YAPAN

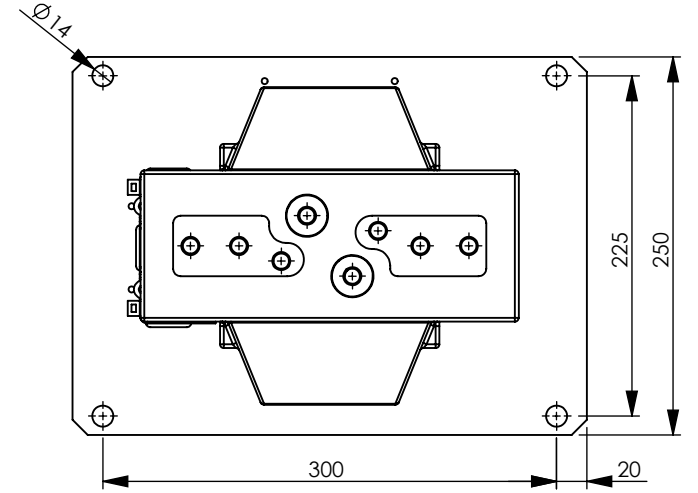

PRİMER BAĞLANTI TERMİNALLERİ

Diş	SIKMA TORKU
M5	2-2,5
M8	16-20
M12	60-70

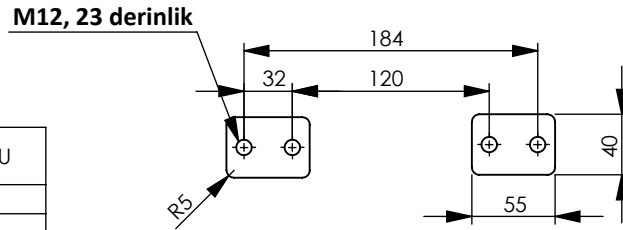

800A'e kadar (Pirinç)
800A < In ≤ 1500A (Bakır)

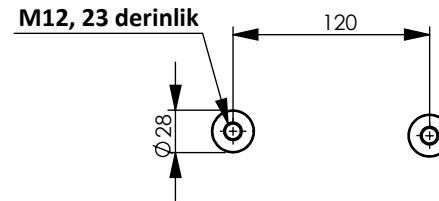

300A'e kadar (Pirinç)
300A < In ≤ 600A (Bakır)

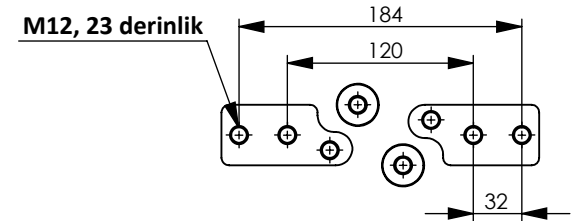

2x300A < In ≤ 2x600A

Genel Toleranslar-General Tolerances (DIN 7168 m)						Parça Adı-Part Name		Malzeme-Material		Tarih-Date	İmza-Signature	Sayfa-Sheet	1/1
0,5-6	6-30	30-120	120-400	400-1000	1000<	ARCT-M36/2 AKIM TRANSFORMATÖRÜ		Çizen-Drawn By		13.12.2021		Ölçek-Scale	A4 1:10
±0,1	±0,2	±0,3	±0,5	±0,8	±1,2	Resim No-Draw No		Kontrol-Checked By				Yön-Direction	→ ⊕
Açısal Toleranslar-Angular Tolerances						CTOG_00002		Ağırlık- Weight (gr.)		21355.72			
<10°	10°<50°	50°>120°	>120°			e-MOR:		Kaplama Cinsi-Plating Type					
±1°	±0,5°	±0,3°	±0,2°			Kap. Kalınlığı-Plating Thick.		µ		576158.77			