

REVİZYONLAR

REV. NO	AÇIKLAMA	TARİH	REVİZYON YAPAN
---------	----------	-------	----------------

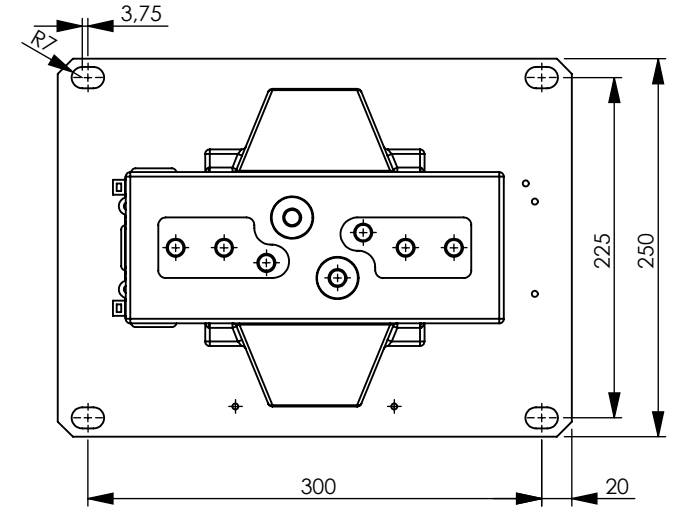
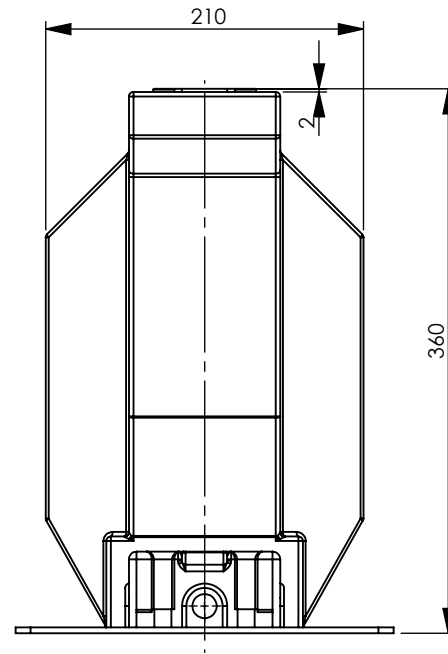
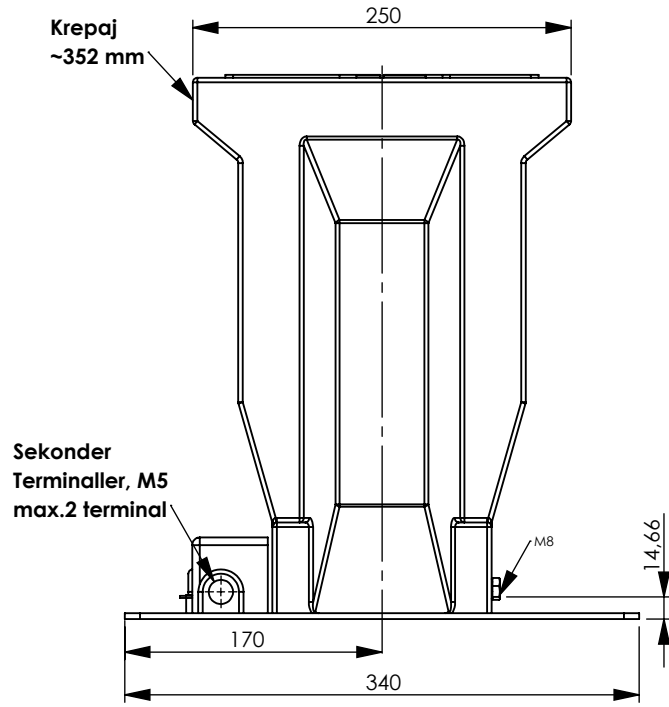

PRİMER BAĞLANTI TERMİNALLERİ

DİŞ	SIKMA TORKU
M5	2-2,5
M8	16-20
M12	60-70

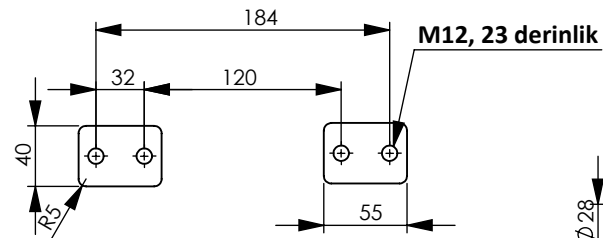

800 A'e kadar (Pirinç)
800A < I_n ≤ 1500A (Bakır)

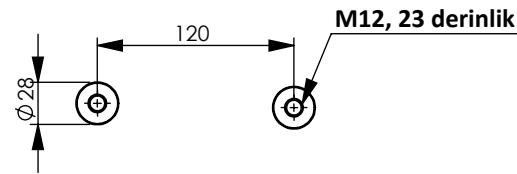

300 A'e kadar (Pirinç)
300A < I_n ≤ 600A (Bakır)

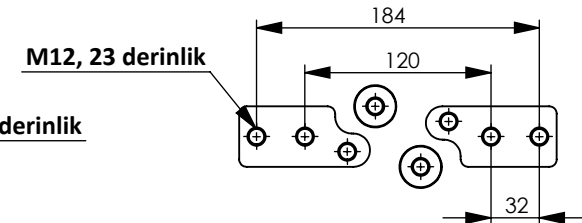

2x300A < I_n ≤ 2x600A

Genel Toleranslar-General Tolerances (DIN 7168 m)						Parça Adı-Part Name		Malzeme-Material		Tarih-Date	İmza-Signature	Sayfa-Sheet	1/1	
0,5-6	6-30	30-120	120-400	400-1000	1000<	ARCT-M36/1 AKIM TRANSFORMATÖRÜ		Çizen-Drawn By		13.12.2021		Ölçek-Scale	A4 1:10	
±0,1	±0,2	±0,3	±0,5	±0,8	±1,2	Resim No-Draw No		Kontrol-Checked By				Yön-Direction	→ ⊕	
Açısal Toleranslar-Angular Tolerances						CTOG_00001		Ağırlık- Weight (gr.)		20660,27				
<10°	10°<50°	50°>120°	>120°	e-MOR:		Kaplama Cinsi-Plating Type		Kap. Kalınlığı-Plating Thick.		μ				559297.91
±1°	±0,5°	±0,3°	±0,2°											